



*An add-on to
Alliance Access*

Benefits

- Shields your securities settlement application from T2S message handling complexity
- No exposure to T2S VAN protocol
- Applicable to all T2S flows (store-and-forward, real-time)
- Handles T2S specific messaging requirements (signature creation/verification, compression/decompression, bulking/debulking, timeout and oversize management)

Connector for T2S – easing T2S access over SWIFT

Shielding you from T2S message handling complexity

Integrating T2S messaging flows with back office operations will pose an operational challenge for many organisations. A sensible approach is to leverage existing systems and workflows wherever possible in order to reduce costs, increase efficiency and reduce maintenance efforts.

If Alliance Access is already in place for handling other types of traffic, it is worth looking at what it can offer in the specific context of T2S. Although it is technically possible to connect directly to Alliance Gateway using a qualified InterAct and FileAct interface, using Alliance Access for T2S messaging gives you flexibility and choice in terms of bringing your business and back office applications in line with T2S requirements. It means you continue to use the quality, highly reliable interface that is already integrated with your operations.

As Alliance Access is both a strategic platform for SWIFT and one of the leading messaging interfaces in the industry, you can be confident that it will continue to be the foundation for both SWIFT and third-party solutions moving forward.

As an add-on to Alliance Access, SWIFT's new Connector for T2S handles a number of T2S integration challenges directly within Alliance Access, allowing you to focus your resources on business-related aspects of T2S implementation.

What is Connector for T2S?

Connector for T2S is a product developed by SWIFT to facilitate T2S communication flows to and from T2S over the SWIFT's Value Added Network (VAN) solution for T2S.

The main objective of Connector for T2S is to simplify connectivity between your settlement application and T2S.

With Connector for T2S in place, your settlement application is shielded from messaging complexity and needs to deal only with T2S business information.

Connector for T2S handles settlement instructions, advices, reports and query/response messages, as well as the creation of signatures and compression/decompression of T2S related messages and files.

In addition, Connector for T2S can handle bulking/debulking logic.

As the diagrams show, Connector for T2S significantly decreases the complexity of your operational set-up to connect to T2S.

What do I need to take advantage of Connector for T2S?

Connector for T2S is an add-on to Alliance Access. Therefore in order to take advantage of Connector for T2S you need to use Alliance Access as your messaging interface and subscribe to the SWIFT's VAN solution for T2S.

Do I have to use Connector for T2S if I want to connect to the SWIFT's VAN solution for T2S?

No, your Alliance Access interface, as of patch 7.0.75, is fully ready for the SWIFT's VAN solution for T2S.

The Connector for T2S is optional, but it will take T2S connectivity one step further by simplifying much of the message and file handling complexity between your back office application(s), your Alliance Access interface and the T2S system.

T2S complexity without Connector for T2S

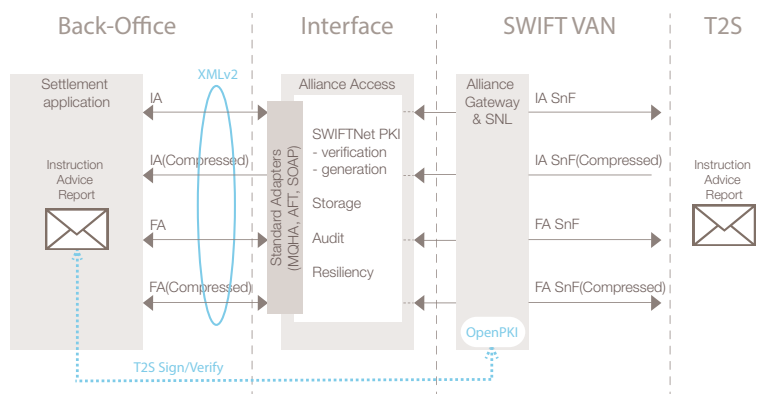

When using standard Alliance Access features, the settlement application is exposed to the T2S VAN protocol and is responsible for handling the appropriate InterAct/FileAct messages to exchange the T2S messages in ISO 20022 format.

T2S with Connector for T2S

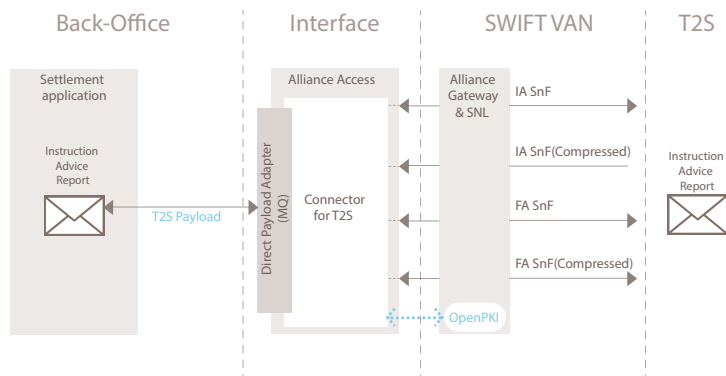

When using Connector for T2S, the settlement application simply exchanges the T2S messages in ISO 20022 format with Alliance Access.

Note: Connector for T2S supports also real-time flows over SWIFT's VAN (not illustrated).

What do I need to do to get Connector for T2S up and running?

The Connector for T2S is 'powered by' the Alliance Access Integration Platform and comes with ready to use integration flows supporting the core T2S functions.

SWIFT Consulting will take care of the setup and configuration.

Connector for T2S can be further customised to address specific customer integration needs (for example, different back office formats, adaptation of integration flows and different handling of exception processing).

Such configuration can be done by SWIFT Consulting at the request of customers.

When will Connector for T2S be available?

Connector for T2S is available since 28 March 2014.

How much does Connector for T2S cost?

Prerequisites

- Decision to use the SWIFT's VAN solution for T2S
- Alliance Access interface

Price principles

- One-time fee plus recurring maintenance (20%) covering Connector for T2S and the usage of Integration Platform for customisation of integration flow (in the scope of T2S only)
- Setup and configuration consultancy fees
- Separate licensing of Integration Platform licence is required in case ISO 20022 support is needed (for message generation and/or transformation from ISO 15022) or for development of non-T2S based integration flows
- Alliance Access band based

For more information, please contact your SWIFT account manager or email us at swift.T2S.team@swift.com.